

GYROCOMPASS CMZ900 series



CMZ900 GYROCOMPASS

is highly reliable and long life.

A gyrocompass detects the true north by means of a fast-spinning rotor, which is suspended with no friction and is influenced by gravity and rotation of the Earth. A gyrocompass consequently indicates a ship's heading.

CMZ900 series has been type approved in accordance with International Maritime Organization (IMO) standards, resolution A.424(XI).



CONTROL BOX
(MKC 326/327)

MASTER COMPASS
(MKM 026)

FEATURES

- A modular design saves the space. MASTER COMPASS can be integrated in the autopilot steering stand.
- Manual and automatic speed error correction
- External heading sensor can back up the heading outputs.
- Serial data output IEC 61162-2 (high-speed transmission)
- A unique anti-vibration mechanism enhanced by the velocity damping effect of high viscous oil, provides superior damping of vibration and decoupling of shock at sea.
- A small and lightweight container enhances the follow up speed. The gyrocompass reading changes smoothly and does not lag when a small ship rapidly changes course.
- Easy maintenance and long maintenance periods

Titanium capsule and electrodes are employed for GYROSPHERE. Purity is maintained inside of the container, and maintenance interval is then longer-dated.

The container is divided into two pieces at bottom when overhauled. Ship's crew can replace GYROSPHERE in case of emergency.

PERFORMANCE SPECIFICATIONS

- Accuracy:
 - Static: 0.25° sec Lat.
 - Dynamic: 0.7° sec Lat.
- Settling time: Within 5 hours
- Follow up accuracy: 0.1 or less
- Max. follow up speed: 30/sec
- Permissible roll and pitch angle: 40
- Permissible ambient temperature:
 - Operation: -10C to +55C



Easy maintenance

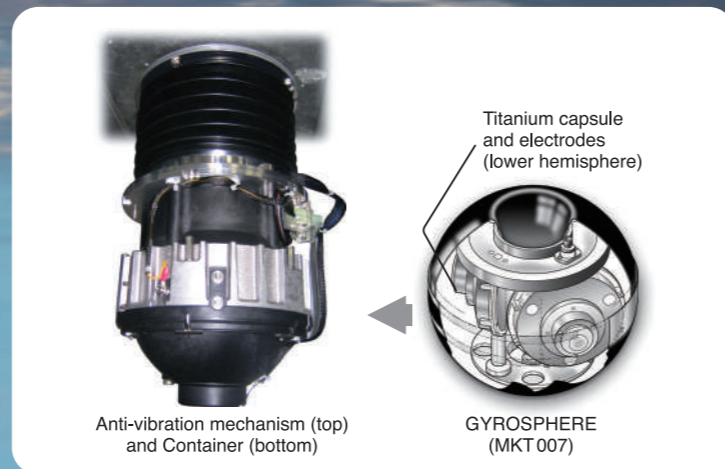

Anti-vibration mechanism (top) and Container (bottom)

GYROSPHERE (MKT 007)

SYSTEM CONFIGURATIONS

Three types of system configuration are provided on CMZ900 series as per specification requirements of functionality, the amount of signal outputs and redundancy.

- CMZ900B2: Single-unit model, suitable for small vessels
- CMZ900S: Single-unit model, suitable for all types of merchant vessels
- CMZ900D: Dual-unit model for extra reliability

Basic configuration of each type of CMZ900 series is illustrated below. Viewing enhancement of the system capability, optional instruments are available in order to increase the signal outputs of the gyrocompass. Other navigation equipment such as repeater compasses, course recorder are available as a part of the system.

MASTER COMPASS (MKM 026/029) runs on 24 VDC power supply. It is easily adopted to the power supply requirements, and all signal outputs can then be maintained during AC power interruption if 24 VDC is provided.

Serial data output IEC 61162-1 or -2 (high-speed transmission) is selective, and contains the ship's heading and rate of turn (ROT) information.



GYROSPHERE (MKT 007)
is incorporated in MASTER COMPASS.

CMZ 900B2 type

MASTER COMPASS (MKM 029)

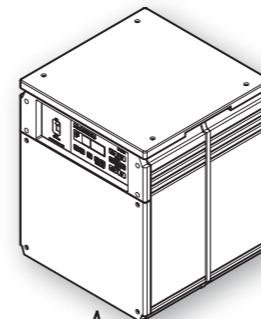

· Buzzer stop
· External heading data

· Repeater compasses
· Steppers
· Serial data (IEC 61162-1/2)
· Analog outputs (Rate of turn, Course recorder)
· Alarms

AC ADAPTER (MKS 070)

Power supply
· 100/110/115/220 VAC
· 50/60 Hz single-phase
· 24 VDC for back-up

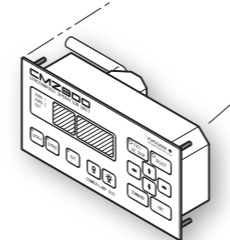

C. OPERATION UNIT (MKR 040)
Note : Built in MKM 029

CMZ 900S type

MASTER COMPASS (MKM 026)

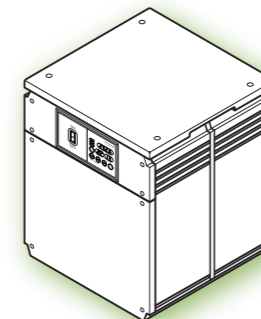

· Serial data (IEC 61162-1/2)
· Analog outputs (Rate of turn, Course recorder)

CONTROL BOX (MKC 326)

· Buzzer stop
· External heading data (IEC 61162-1)
· Ship's speed and Latitude data for the automatic speed error correction (IEC 61162-1)

· Repeater compasses
· Steppers (Option)
· Running status and Alarms

Power supply
· 100/110/115/220 VAC
· 50/60 Hz single-phase
· 24 VDC for back-up

CMZ 900D type

MASTER COMPASS (MKM 026)

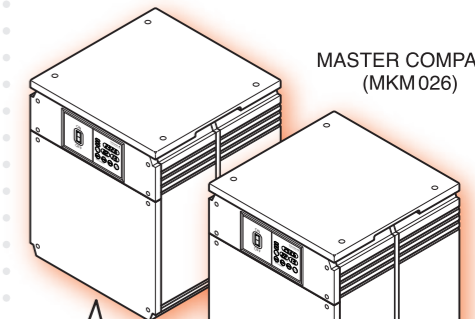

MASTER COMPASS (MKM 026)

· Identical inputs with CMZ900S

· Repeater compasses
· Steppers
· Serial data (IEC 61162-1/2)

· Analog outputs (Rate of turn, Course recorder)
· Running status and Alarms

CONTROL BOX (MKC 327)

Power supply
· 100/110/115/220 VAC
· 50/60 Hz single-phase
· 24 VDC for back-up

DUAL AC ADAPTER (MKS 071)

CMZ900B is available when MED certificate is not required.

OUTLINE DIMENSIONS

MASTER COMPASS
(MKM026) MASS: 43 kg

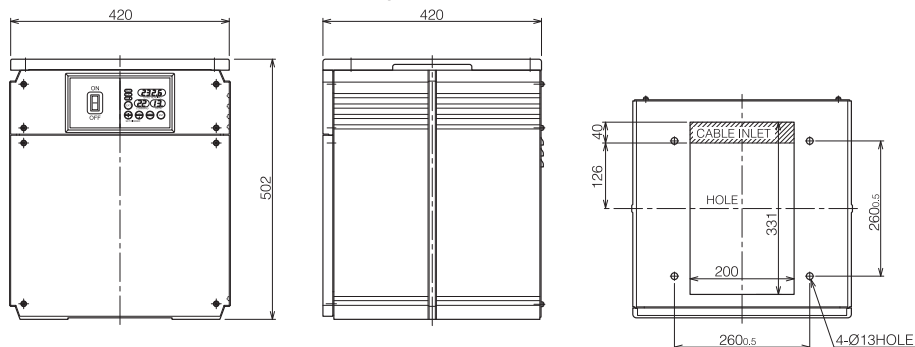

CONTROL BOX
(MKC 326) MASS: 17 kg

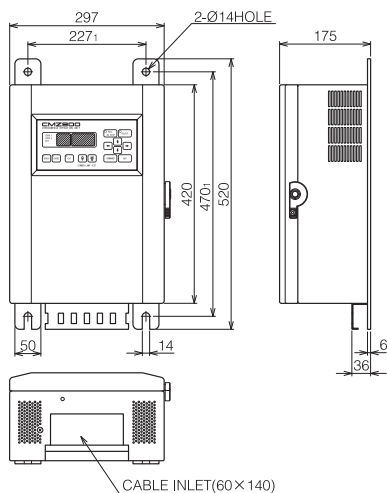

CONTROL BOX
(MKC 327) MASS: 16 kg

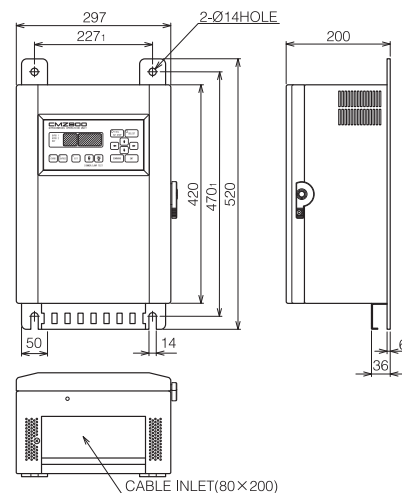

AC ADAPTER
(MKS070) MASS: 10.5 kg

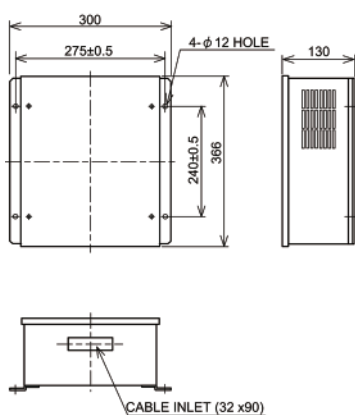

DUAL AC ADAPTER
(MKS071) MASS: 20 kg

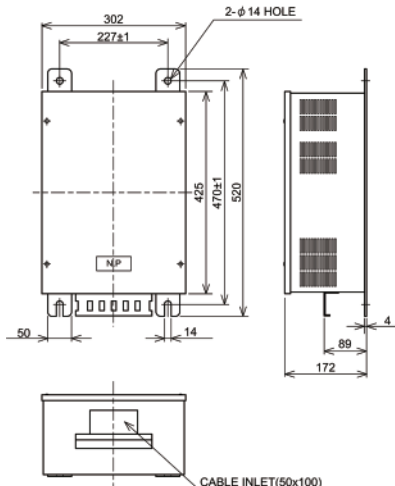

Dimensions in mm
Flush mounting type of CONTROL BOX and DUAL AC ADAPTER are available.

Caution : Please read the manual before using this product.

YDK Technologies Co., Ltd.

URL : <https://www.ydktechs.co.jp>

Marine Equipment Business Division

Address : **Minami Shinjuku Hoshino Bldg.**

5-23-13 Sendagaya, Shibuya-ku, Tokyo, 151-0051 JAPAN

International Sales Dept. Phone : (81) 3-3225-5383 FAX : (81) 3-3225-5316

Service Dept. Phone : (81) 3-3225-5392 FAX : (81) 3-3225-5316

Domestic Sales Dept. Phone : (81) 3-3225-5382 FAX : (81) 3-3225-5316

Osaka Branch Phone : (81) 6-6345-8566 FAX : (81) 6-6345-8567

Imabari Branch Phone : (81) 898-22-4559 FAX : (81) 898-33-2005

Nagasaki Branch Phone : (81) 95-826-5552 FAX : (81) 95-826-5553

Subject to alteration due to technical developments without notice

Represented by :